

- TEFC, IP54/ IP55 Rating (IP55 for Motor Frame Sizes 5000 and Larger).
- Cast Iron Frame, End Brackets, Fan Cover and Terminal Box
- Multi-Mount Construction (145T/ 143T Drilled Foot Holes Up Through 449T Frame)
- Automatic Grease Discharge Fittings Protects the Vacuum De-Gassed Re-Greasable Motor Bearings From Over Pressure
- Vacuum De-Gassed Re-Greasable Ball Bearings (or Rollers) Using Polyrex EM Grease on 280TS Frames
- Paint System: Phenolic Rust Proof Base Plus Polyurethane Top Coat (Color: Light Grey - Munsell N5.0)
- Labyrinth-Type Metal Flinger on Both Ends of 280TS to 6800 Frames.

- Internal Components with Class F Insulation, 2 Dips in PAR Varnish then Bake
- Designed for 40°C Ambient Conditions with Class B Temperature Rise
- 1045 Carbon Steel Shaft with Bi-directional Rotation (2 Pole Motors Having 5000 Frames and Larger are Uni-Directional)
- Aluminum Die Cast, Squirrel Cage Rotor for Smaller Motors (5000 Frame and Smaller), Copper/ Copper Alloy Rotor for Larger Motors (5800 Frame and Larger).
- Insulated, Non-Drive End Bearings on 2 Pole Motors, 600 hp and Larger

- Stainless Steel Name Plate
- Voltage Requirements: 3 Phase, 60 Hz, 230/460V (usable on 208V), 575V Motors Available. De-Ratable for 190/380V, 50 Hz Motors.
- Motors 150 hp and Larger are 460V only.
- Foot Mounted with C-Flange or Round Body with C-Flange: 1-300 hp
- 1.15 Continuous Service Factor

- Oversized Terminal Box, Rotatable in 90° Increments, Fully Gasketed, NPT Entrance
- Inverter Duty Service Capability, Single Shielded Bearings, Ground Terminal in Terminal Box, Inverter Duty Magnet Wire Capable of Withstanding Voltage Spikes of Up to 2200V
- UL Recognized and CSA Approved for Inverter Duty Per NEMA Standards (Service Factor: 1.0)
- ** - 6 Leads (150 hp and Larger)
- ** - 9 Leads (5 hp and Smaller)
- ** - 12 Leads (7.5 - 125 hp)

MAX-E1®

Totally Enclosed Fan Cooled
Severe Duty



TECO **Westinghouse**

5100 N. IH-35
Round Rock, Texas 78681
1-800-873-8326 (USE-TECO)
www.tecowestinghouse.com

SM-MXE1 10-15



MAX-E1® FEATURES AND BENEFITS

Product Scope	
Horsepower	3/4 to 800 hp
Speed	3600, 1800, 1200, or 900 RPM
Voltage	230/460V or 575V 150 hp and larger are 460V only
Enclosure	Totally Enclosed Fan Cooled
Frame Size	143T through 6808
Construction	Cast Iron
Vibration (Unfiltered)	Per NEMA MG 1, Sec. 1, Paragraph 7.8.1: Velocity < 0.15 in/sec (peak) Displacement < 0.0025 in (p-p) Acceleration ≤ 1g (peak)
Insulation	Class F, Exceeds NEMA MG 1, Part 31 (Inverter Duty)

The TECO-Westinghouse MAX-E1® product line offers a broad range of NEMA Premium Efficiency motors from 3/4 hp to 800 hp that are suitable for any general purpose application and can meet most specific industrial requirements.

MAX-E1® motors are TOTALLY ENCLOSED FAN COOLED, squirrel-cage induction motors that are designed, manufactured and tested to meet or exceed the latest NEMA, IEEE, and other international standards. All motors are CSA certified for Class I, Division II, Groups B, C, and D; temperature code T3C and have a non-sparking, non-static fan. These motors are suitable for severe applications in environments with excessive dirt, dust and/or moisture. The unique design, first-grade material and excellent workmanship of the MAX-E1® make TECO-Westinghouse motors last much longer and provide cost-efficient operation.



MAX-E1® NEMA Premium Efficiency Motor



Frames 140T - 210T



Frames 250T - 440T



Frames 5800 and Larger

POWER SUPPLY:

MAX-E1® motors will operate satisfactorily on voltages within +/- 10% fluctuation of rated voltages; or frequency within +/- 5% combined fluctuation, not to exceed 10%.

AMBIENT TEMPERATURE:

Standard ambient temperature is -20°C to 40°C (104°F), however, motors with 1.15 service factor can be operated at an ambient temperature up to 50°C (122°F) at a 1.0 service factor.

For lower or higher ambient temperature applications, refer to TECO-Westinghouse for modification options.

ALTITUDE:

Standard MAX-E1® motors can operate at all altitudes up to 9,900 feet (3,000 meters) with a service factor of 1.15. Motors having a service factor of 1.0 can operate at altitudes up to 3,300 feet (1,000 meters).

TYPICAL APPLICATIONS:



- Crushers, Grinders
- Compressors
- Reciprocating Machinery
- Water and Wastewater
- Mixers
- Positive Displacement Pumps
- Commercial Washing Machines
- Material Handling
- Warehouse Automation
- Stamping, Punch Press



MODIFICATIONS AVAILABLE:

- Class F And H Insulation
- Space Heaters
- Thermal Protection
 - Windings
 - Bearings
- Special Paint Finish
- Double End Shaft or Special Shaft Dimensions
- 50 Hz Operation
- Shaft Grounding
- Insulated Bearings
- Blower Kits for VFD Service
- Encoders
- Mounting Flange Options: C or D Design
- Terminal Box Position: F1 or F2
- Contact TECO-Westinghouse for Additional Modifications

MAX-E1® CONNECTION DIAGRAMS:

1) 3/4 hp - 5 hp: Connected Internally

Across-The-Line Starting

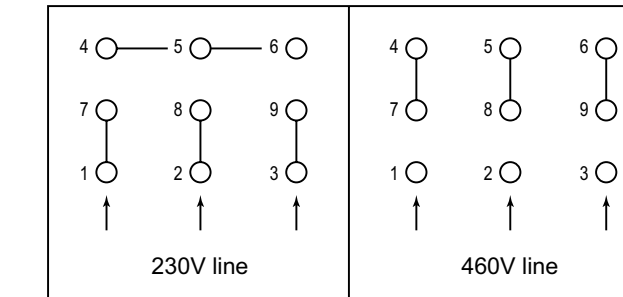

3) 150 hp and Up (6 leads) - 460V only

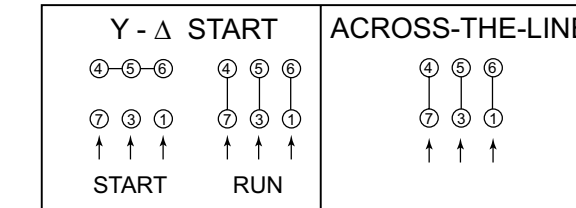

2) 7 1/2 hp - 125 hp: Δ Connected Internally

Up to 125 hp (12 leads)

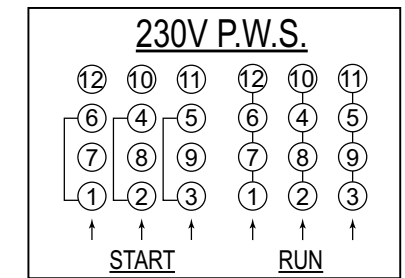
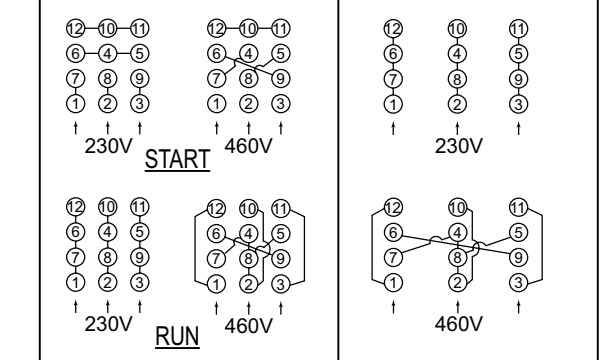

APPLICATION OF V-BELT SHEAVE DIMENSIONS:

To assure satisfactory MAX-E1® motor operation, the selected diameter shall be not smaller than, nor shall the selected width be greater than, the dimensions listed below.

Frame Number	Horsepower at Synchronous Speed, RPM				Conventional		Narrow	
					A, B, C, D, and E		3V, 5V and 8V	
	3600	1800	1200	900	Minimum Pitch Diameter, Inches	Maximum Width, Inches	Minimum Outside Diameter, Inches	Maximum Width, Inches
143T	1.5	1	3/4	-	2.2	4.25	2.2	2.25
145T	2-3	1.5-2	1	-	24.0	4.25	2.4	2.25
182T	3	3	1.5	-	2.4	5.25	2.4	2.75
182T	5	-	-	-	2.6	5.25	2.4	2.75
184T	-	-	2	-	2.4	5.25	2.4	2.75
184T	5	-	-	-	2.6	5.25	2.4	2.75
184T	7.5	5	-	-	3.0	5.25	3.0	2.75
213T	7.5-10	7.5	3	-	3.0	6.51	3.0	3.38
215T	10	-	5	-	3.0	6.51	3.0	3.38
215T	15	10	-	-	3.8	6.51	3.8	3.38
254T	15	-	7.5	-	3.8	7.75	3.8	4.00
254T	20	15	-	-	4.4	7.75	4.4	4.00
256T	20-25	-	10	-	4.4	7.75	4.4	4.00
256T	-	20	-	-	4.6	7.75	4.4	4.00
284T	-	-	15	-	4.6	8.99	4.4	4.62
284T	-	25	-	-	5.0	8.99	4.4	4.62
286T	-	30	20	-	5.4	8.99	5.2	4.62
324T	-	40	25	-	6.0	10.25	6.0	5.25
326T	-	50	30	-	6.8	10.25	6.8	5.25
364T	-	-	40	-	6.8	11.51	6.8	5.88
364T	-	60	-	-	7.4	11.51	7.4	5.88
365T	-	-	50	-	8.2	11.51	8.2	5.88
365T	-	75	-	-	9.0	11.51	8.6	5.88
404T	-	-	60	-	9.0	14.25	8.0	7.25
404T	-	-	50	-	9.0	14.25	8.4	7.25
404T	-	100	-	-	10.0	14.25	8.6	7.25
405T	-	-	75	60	10.0	14.25	10.0	7.25
405T	-	100	-	-	10.0	14.25	8.6	7.25
405T	-	125	-	-	11.5	14.25	10.5	7.25
444T	-	-	100	-	11.0	16.75	10.0	8.50
444T	-	-	75	-	10.5	16.75	9.5	8.50
444T	-	125	-	-	11.0	16.75	9.5	8.50
444T	-	150	-	-	-	16.75	10.5	8.50
445T	-	-	125	-	12.5	16.75	12.0	8.50
445T	-	-	100	-	12.5	16.75	12.0	8.50
445T	-	150	-	-	-	16.75	10.5	8.50
445T	-	200	-	-	-	16.75	13.2	8.50